

Sulfur Dioxide (SO₂) Sensor

110-6xx

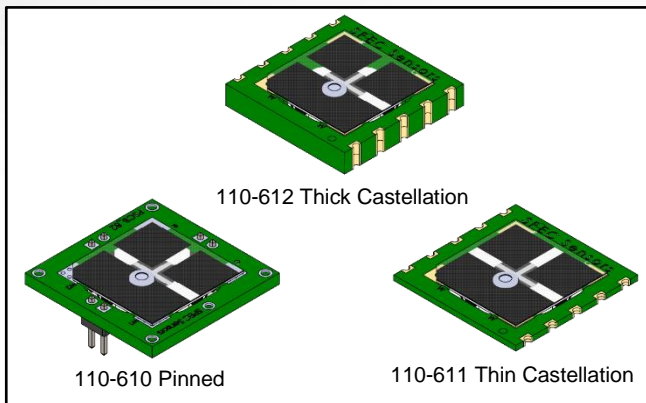
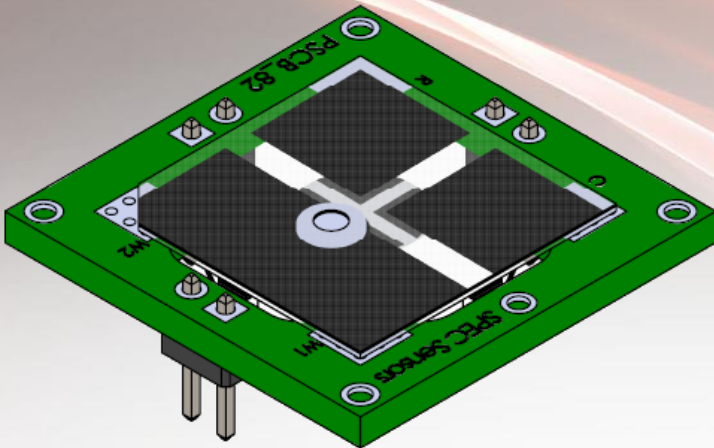

Interlink Electronics Screen Printed Electrochemical sensor (SPEC Sensor™) revolutionizes the current state of the art, enabling new applications in consumer, medical and industrial safety. Interlink Electronics offer the performance of the best quality electrochemical sensors at a fraction of the price. The 110-6xx family Sulfur Dioxide sensors are small and low-profile, facilitating easy integration into wireless, portable, and other IoT solutions. These sensors are ideal for health, food, environmental, industrial, and residential monitoring, because of their high performance, low cost, and small size. IE'S Sulfur Dioxide Sensor are available in three packages (110-610, 110-611, 110-612).

FEATURES

- Small Size & Low Profile
- Improved stability and low ppb sensitivity
- Accurate & Linear Response
- Long Life (10 +years)
- Fast Response
- 100% Factory Tested
- Ultra-Low Power < 50 uW max
- ROHS Compliant

APPLICATIONS

- Outdoor Air Quality
- Indoor Air Quality
- Weather Stations
- Internet of Things
- Smart Homes
- Industrial Safety

The diagram below shows the basic measuring circuit for the 110-6xx. The sensor generates an electric current which is converted into output voltage (Vout) using a linear circuit like the one shown.

Notes: $V_{bias} = V_w - V_r$

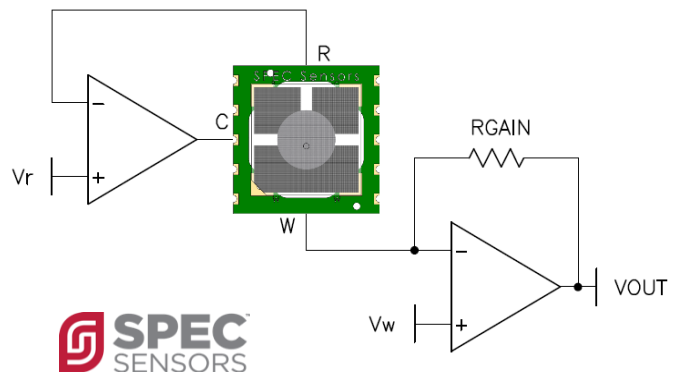

SPECIFICATIONS

Parameter	Typical Value	Unit	Notes
Measurement Range	0 to 20	ppm	1,2,3
Lower Detection Limit	0.02	ppm	1,2
Resolution	0.01	ppm	1,2
Accuracy	± 1	%	1
Response Time – T (90)	< 30	seconds	1
Sensitivity Range	40 ± 15	nA/ppm	1
Expected Operating Life	10	years	1
Operating Temperature Range	-30 to 55	°C	3
Operating Humidity Range	10 to 95	%	3,4
Operating Pressure Range	0.8 to 1.2	atm	3
Operating Bias Range	0	mV	
Power Consumption	10 to 50	uW	2

- At standard conditions (25 °C, 50% RH, 1 atm), unless otherwise indicated.
- Depends on circuit design.
- Recommended operating range. The sensor may be damaged, and warranty voided if operated outside the specified range. For the best optimum accuracy operate sensor at -20 to 40 °C and 15 to 90% RH.
- Non-condensing.

KEY CHARACTERISTICS

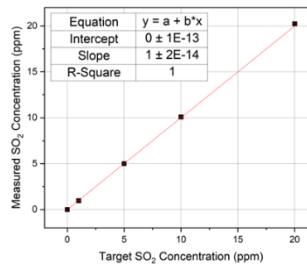
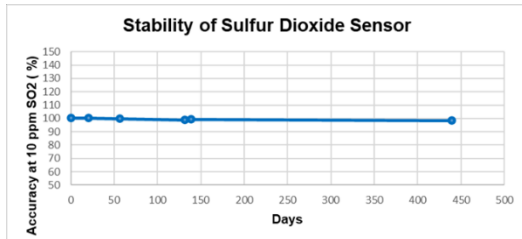

Long Term Stability

Linearity

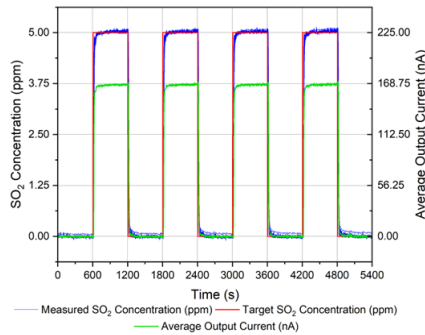

Accuracy

CONTACT US

15707 Rockfield Blvd.
Suite 105
Irvine, CA 92618

Toll Free: +1.866.764.8965
Phone: +1.805.484.8855
Fax: +1.805.530.5598

Visit:

www.interlinkelectronics.com

Email:

sales@interlinkelectronics.com

Information furnished by Interlink Electronics is believed to be accurate and reliable "as is". However, no responsibility is assumed by Interlink Electronics for any use of such information, nor for any infringements of patents or other rights of third parties that may result from its use. Specifications subject to change without notice. No license is granted by implication or otherwise under any patent or patent rights of Interlink Electronics. Trademarks and registered trademarks are the property of their respective owners.