

Indoor Air Quality (IAQ) Sensor 110-8XX

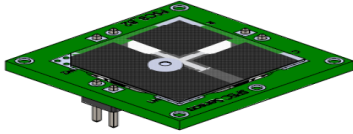

**110-801
Pinned**

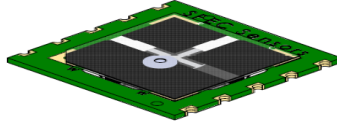

**110-802
Thin
Castellation**

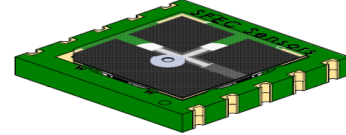

**110-804
Thick
Castellation**

DESCRIPTION

Interlink Electronics Screen Printed Electrochemical sensor (SPEC Sensor™) revolutionizes the current state of the art, enabling new applications in consumer, medical and industrial safety. Interlink Electronics offer the performance of the best quality electrochemical sensors at a fraction of the price. The 110-8xx family IAQ sensors are small and low-profile, facilitating easy integration into wireless, portable, and other IoT solutions. These sensors are ideal for health, environmental, industrial, and residential monitoring, because of their high performance, low cost, and small size. IE'S IAQ Sensor are available in three packages (110-801, 110-802, 110-804).

BENEFITS

- Small Size & Low Profile
- Sensitive in the ppm range
- Not poisoned by sulfides, Chlorides, Ammonia
- Detection of Poor Air Quality gases: Sulfides Alcohols, Ammonia, Odorous gases, and CO
- Accurate & Linear Response
- Long Life (10 +years)
- 100% Factory Tested
- Fast Response
- Ultra-Low Power < 30 uW max
- ROHS Compliant

APPLICATIONS

- Outdoor Air Quality
- Indoor Air Quality
- Weather Stations
- Internet of Things
- Smart Homes
- Early Fire Detection
- Leak Detection
- Ventilation Control

BASIC MEASURING CIRCUIT

The diagram at the right shows the basic measuring circuit of SPEC sensors. The sensor generates an electric current which is converted into sensor output voltage (V_{out}) by an op-amp/resistor combination.

Notes: $V_{bias} = V_w - V_r$

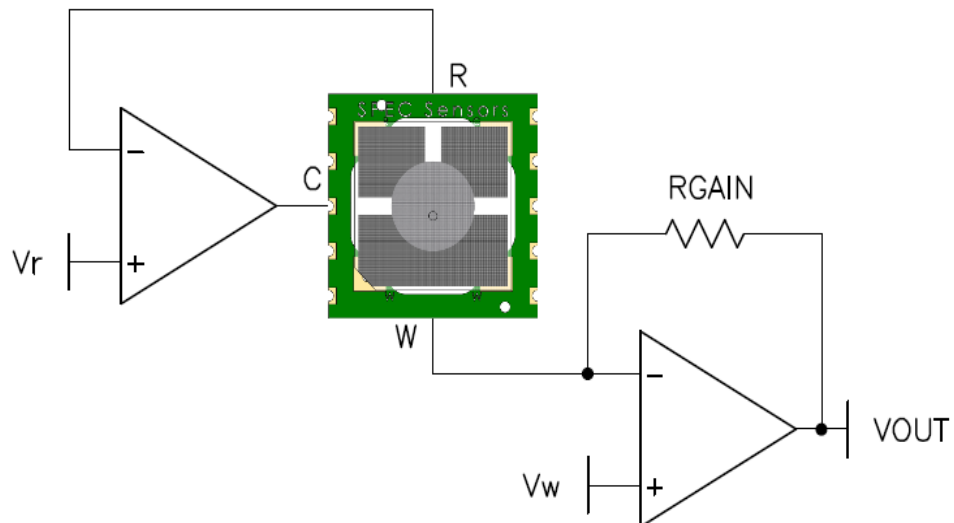

Indoor Air Quality (IAQ) Sensor 110-8XX

TABLE OF CONTENTS

Description.....1

Benefits.....1

Application.....1

Basic Measuring Circuit.....1

Specifications.....3

Cross Sensitivity3

Accuracy4

Linearity.....4

Temperature effect.....5

Long term Stability.....6

Humidity effect.....6

Important Precautions6

Marking Information7

Ordering Information7

Storage and Handling.....8

Dimensions 110-801 Pinned Package9

Dimensions 110-802 Thin Castellated Package.....10

Dimensions 110-804 Thick Castellated Package11

SPECIFICATIONS

Description	Typical	Unit	Notes
Measurement Range	0 to 100	ppm	1,2,3,5
Lower Detection Limit	0.2	ppm	1,2,5
Resolution	0.1	ppm	1,2,5
Accuracy	± 0.5	%	1,5
Response Time – T (90)	< 30	seconds	1,5
Sensitivity Range	20 ± 10	nA/ppm	1,5
Expected Operating Life	10	years	1
Operating Temperature Range	-30 to 55	°C	3,5
Operating Humidity Range	10 to 95	%	3,4,5
Operating Pressure Range	0.8 to 1.2	atm	3
Operating Bias Range	150	mV	
Power Consumption	10 to 50	uW	2

1. At standard conditions (25 °C, 50% RH, 1 atm), unless otherwise indicated.
2. Depends on circuit design.
3. Recommended operating range, The sensor may be damaged, and warranty voided if operated outside the specified range. For the best optimum accuracy operate sensor at -20 to 40 °C and 15 to 90 % RH.
4. Non-condensing.
5. CO equivalents.

CROSS SENSITIVITY

Most chemical sensors exhibit some cross-sensitivity to other gases. The following table lists the relative response of common potential interfering gases, and the concentration at which the data was gathered.

Gas/Vapor	Concentration	Typical Response PPM CO
Carbon Monoxide	50 ppm	50.0
Hydrogen	200 ppm	26.2
Nitrogen Dioxide	5 ppm	0.6
Ozone	0.82 ppm	-0.3
Sulfur Dioxide	10 ppm	6.6
Hydrogen Sulfide	25 ppm	118.6
Ethanol	200 ppm	221.4
Formaldehyde	10 ppm	22.1
Ethylene	50 ppm	83.0
Chlorine	10 ppm	-3.9
Nitric Oxide	10 ppm	15.9
Ammonia	100 ppm	-0.3

ACCURACY

The Figure shows response of a set of 57 sensors exposed 4 times 50 ppm CO test gas. Data showed sensors accuracy at 50 ppm within less than $\pm 0.5\%$. Sensors are calibrated at 50 ppm test gas.

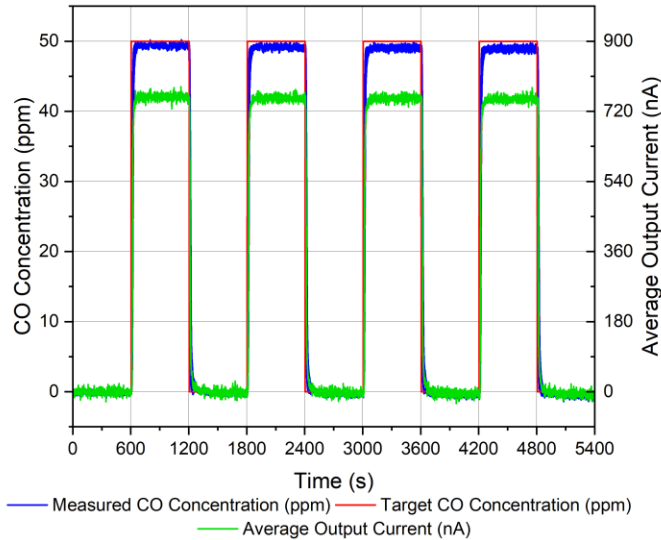

LINEARITY

The Figure shows response of a set of 57 sensors exposed to 20, 50, 100 and 150 ppm CO test gas. Data showed sensors output is linear from 0 to 150 ppm. Sensors are calibrated at 50 ppm CO gas.

This stepped gas test shows the robustness of the sensor with fast response at each step.

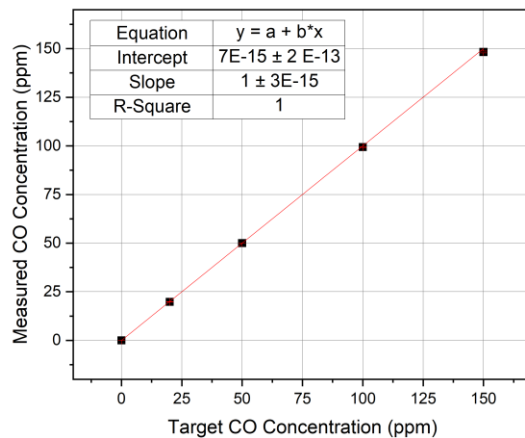
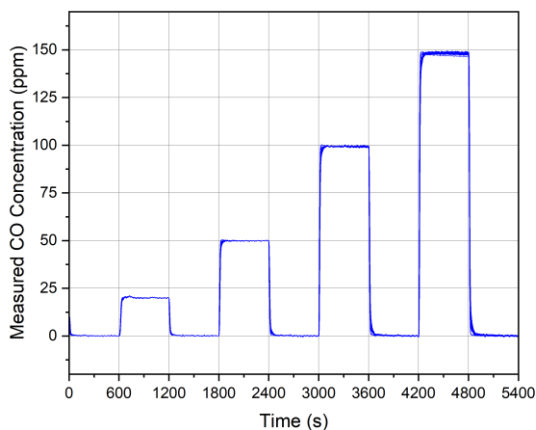

TEMPERATURE EFFECT

Temperature fluctuations have a predictable, easily compensated effect on the sensor signal. The figures below show the typical Temperature dependency of the output and baseline of IAQ sensor under constant humidity of 40-50 % RH. This is a very uniform and repeatable effect, easily compensated for in hardware or software.

Baseline (Normalized to 20 C):

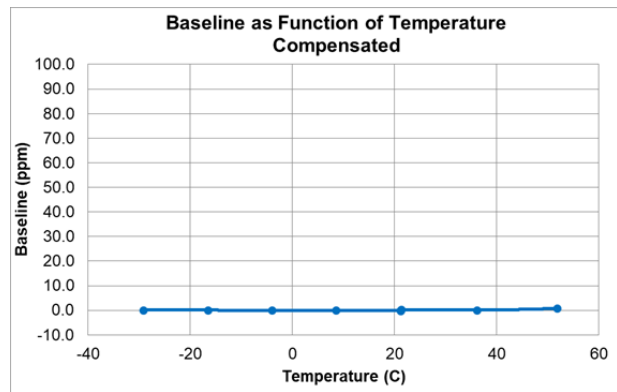
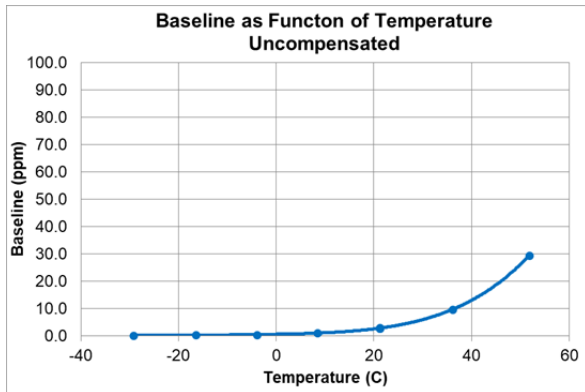

Sensitivity (Normalized to 20 C):

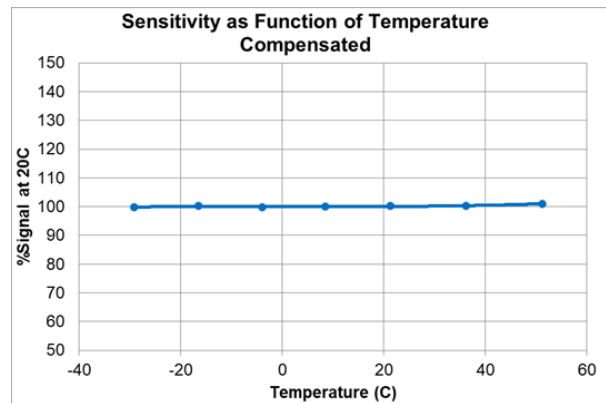
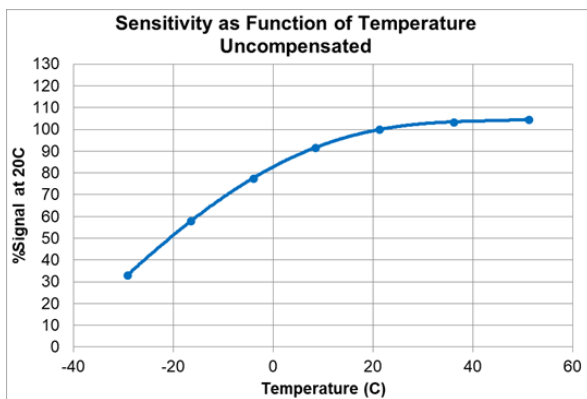

LONG TERM STABILITY

The figure at right shows response of a set of 57 IAQ Sensors over 14 months under standard test conditions. Sensor output is plotted as % of the initial response to 150ppm CO test gas.

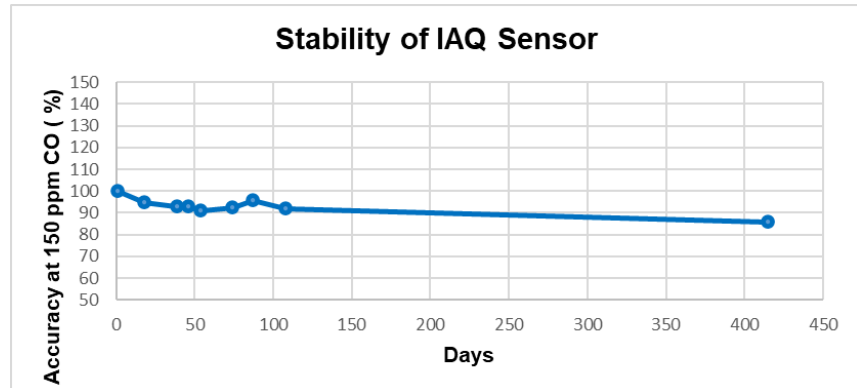

HUMIDITY EFFECT

SPEC IAQ sensors have been tested under a range of humidity conditions to ensure stable response during periodic exposure to varying conditions.

As shown in figure at right, presenting data collected over 6 weeks, the response of the sensors remains within $\pm 5\%$ of the initial signal over the 6-week test period.

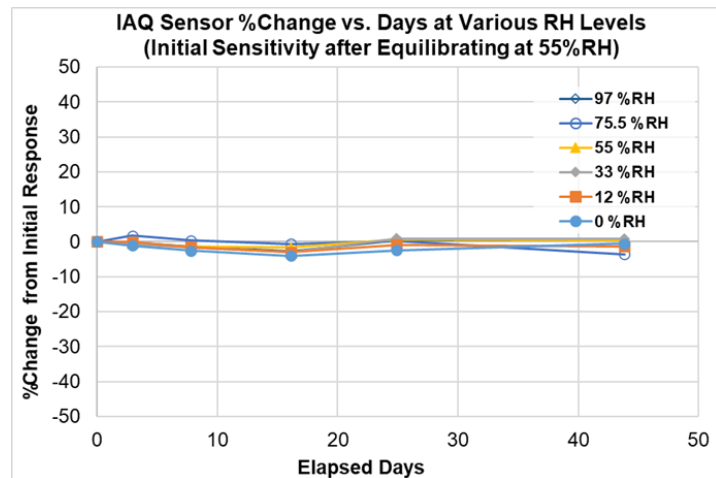

IMPORTANT PRECAUTIONS

All sensor designs are made for air monitoring @ 1 atm +/- 0.2 atm. Because applications of use and device implementation are outside our control, SPEC Sensors cannot guarantee performance in a given device or application, and disclaims any and all liability, therefore. **Customers should test under their own conditions to ensure the sensors are suitable for their requirements.**

Contact the factory to discuss specific concerns that might damage the sensor performance or life.

- Condensation and Water (1)
- Saltwater Contamination (1)
- High Temperature Operation (> 70C) for more than 1 month
- Low Humidity Operation (< 15% RH) for more than 3 months
- High Bias voltage
- Highly contaminated air over a prolonged period
- High levels of particles or soot (unless proper filtering is provided)

(1) Use of porous PTFE membrane or filter cap may address this concern)

MARKING INFORMATION

All gas sensors are tested and marked at the Interlink electronics factory. Sensors include a label with an alpha-numeric code and a two-dimensional bar code. The codes include the information indicated in the table below.

	Sensor Serial Number	Sensor Part Number	Target Gas	Date Code (YYMM)	Sensitivity (nA/ppm)
Alpha-Numeric Code		110802	IAQ	1810	16.93
Two-Dimensional(2D) bar code	101118010250	110802	IAQ	1810	16.93

ORDERING INFORMATION

Part Number	Package
110-801	Pinned
110-802	Thin Castellation
110-804	Thick Castellation

SENSOR STORAGE, HANDLING AND SOLDERING

This information embodies various general recommendations concerning the storage, handling, and manual soldering conditions for Sensor. Moreover, sensors are NOT warranted and should NOT be used in high temperature soldering (reflow) or pre-tinning baths.

Sensor & Module Handling

Handle sensors with care. Take precautions, including but not limited to the following:

- A. DO NOT apply excessive pressure to the top or bottom of the sensor module.
- B. Whenever possible, handle or contact the sensor module from the sides of the PCB or substrate.
- C. Light vacuum pressure is possible during handling, DO NOT apply vacuum over gas sensor port.
- D. If the sealed sensor package is opened, DO NOT re-seal use vacuum or nitrogen gas. DO NOT reseal with desiccant.
- E. DO NOT obstruct the gas sensor port by making direct contact with any tape, apparatus, weights, etc.
- F. DO NOT use silicone or other conformal coatings around the sensor or gas portholes.
- G. Operators are requested to wear powder-free antistatic gloves.

Manufacturing Assembly Floor Environment

Interlink Electronics recommends that the manufacturing assembly floor environment be maintained at controlled conditions:

- A. Temperature: 18 - 26°C
- B. Relative Humidity: 40 to 60%
- C. Pressure: 1.0 ± 0.2 atm

Sensor & Module Storage Conditions

The shelf life for sealed, packaged components is 12 months from the pack seal date, when stored in the factory-sealed bag under the following conditions:

- A. Temperature: 5 to 25 °C
- B. Relative Humidity: 20 to 80%
- C. Pressure: 1.0 ± 0.2 atm
- D. Storage Time: 12 months

When moving from Storage Conditions to the Manufacturing Assembly Floor Environment, the sensors should be allowed to equilibrate at the new conditions for at least 24 hours prior to manufacturing.

Module Attach Soldering Process

Hand solder only. Keep the soldering iron or solder process tool away from the sensor. The sensor should not see pre-heat temperatures above 70 °C. There have been suggested cases where a heat sink cover over the sensor may be applicable to protect the sensor during processing. No Application notes to this approach available. Only to be used as reference only.

- A. DO NOT heat sensor above 70 °C.
- B. Hand or peripheral process type approach
- C. Use solder wire alloy with the lowest possible eutectic temperature.
- D. Use the lowest possible soldering iron temperature.
- E. Contact the host board with the soldering iron at a 45° angle on the solder pad.
- F. Keep the soldering iron away from the top and bottom of the sensor module.
- G. DO NOT place in reflow, wave or IR reflow type processes.
- H. DO NOT place mounted board in a wash.

110-801 Pinned Package

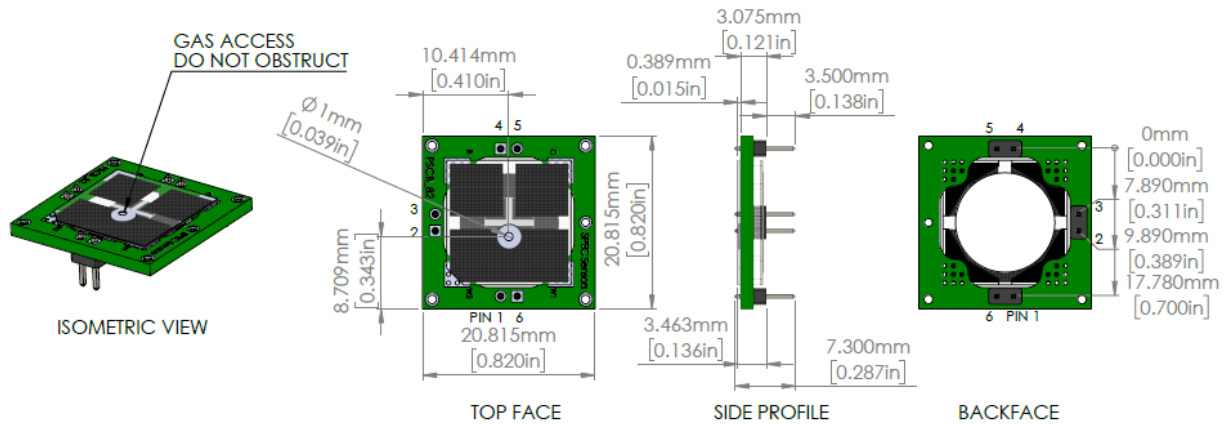

PIN	CONNECTION
1	WORKING
2	N/A
3	N/A
4	REFERENCE
5	COUNTER
6	WORKING

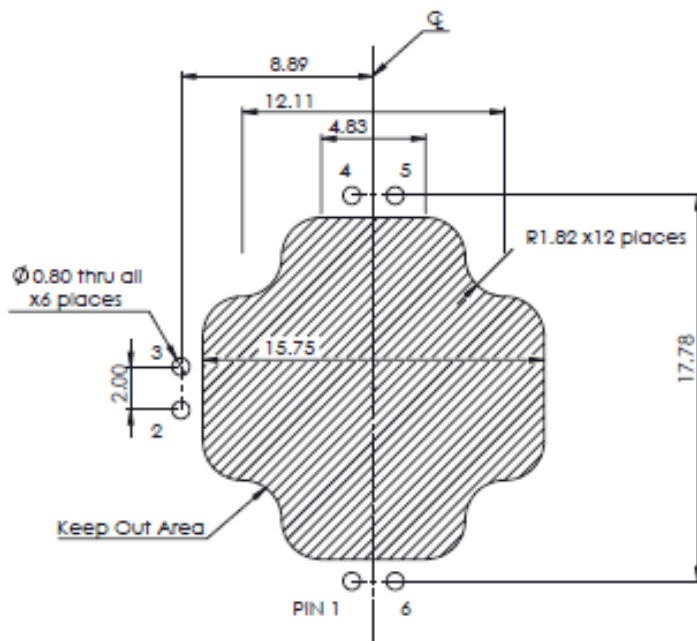

Dimensions are in millimeters

PIN	CONNECTION
1	WORKING
2	NC
3	NC
4	REFERENCE
5	COUNTER
6	WORKING

Notes:
 -(Ø) 0.8 mm drilled diameter Holes
 -Recommended Socket
 (for removable sensor option)
 PN: 3M 950502-60102-AR
 -If using socket, keep out area
 may not be required. Use caution.

110-802 Thin Castellation Package

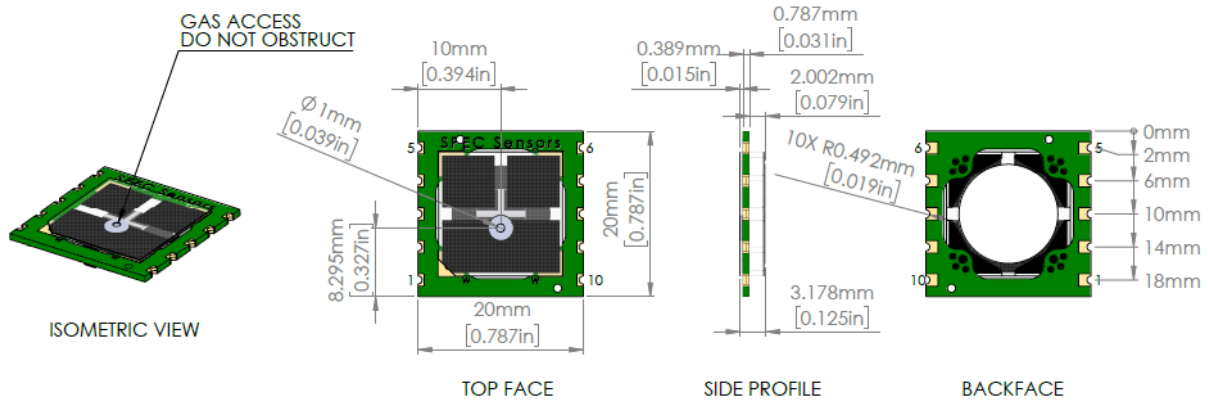

PIN	CONNECTION
1	WORKING
2	NC
3	NC
4	NC
5	REFERENCE
6	COUNTER
7	NC
8	NC
9	NC
10	WORKING

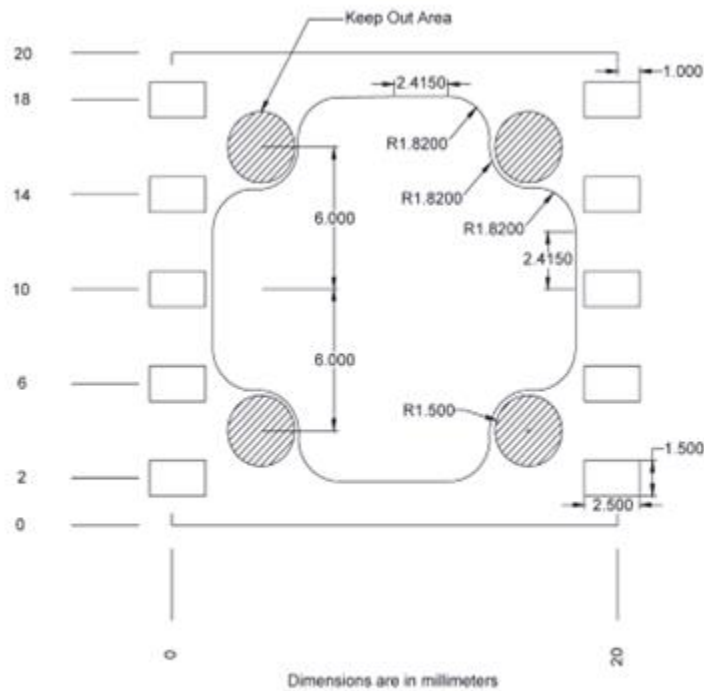

110-804 Thick Castellation Package

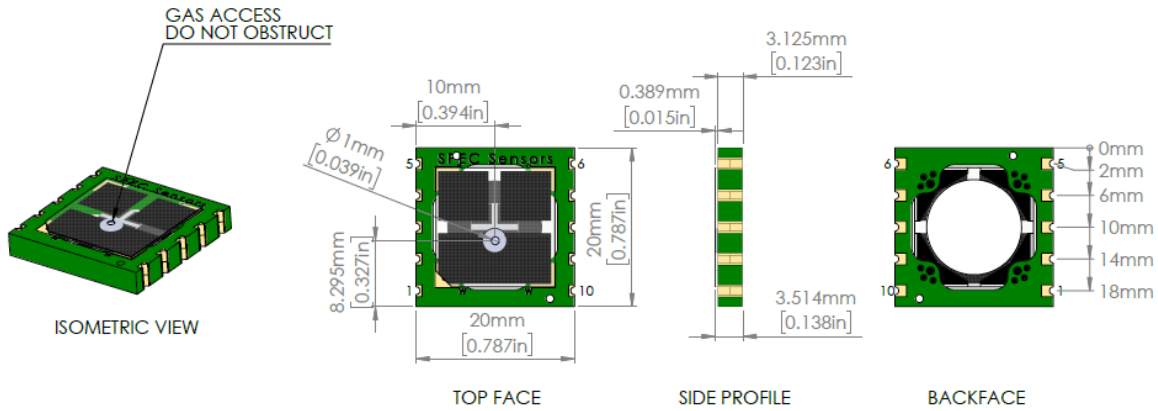

PIN	CONNECTION
1	WORKING
2	NC
3	NC
4	NC
5	REFERENCE
6	COUNTER
7	NC
8	NC
9	NC
10	WORKING

