

## Respiratory Irritant (RESP) Sensor 110-9XX

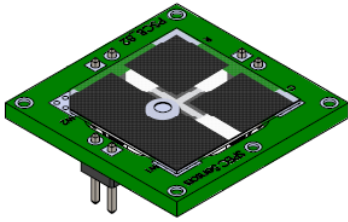

**110-901**  
**Pinned**

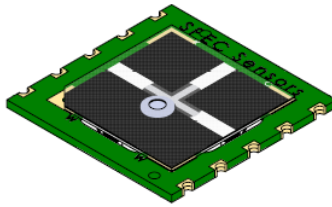

**110-902**  
**Thin**  
**Castellation**

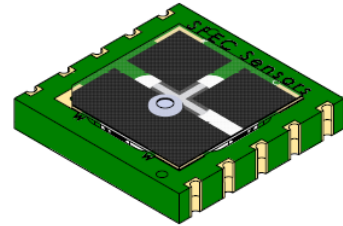

**110-904**  
**Thick**  
**Castellation**

### DESCRIPTION

Interlink Electronics Screen Printed Electrochemical sensor (SPEC Sensor™) revolutionizes the current state of the art, enabling new applications in consumer, medical and industrial safety. Interlink Electronics offer the performance of the best quality electrochemical sensors at a fraction of the price. The 110-9xx family RESP sensors are small and low-profile, facilitating easy integration into wireless, portable, and other IoT solutions. These sensors are ideal for health, environmental, industrial, and residential monitoring, because of their high performance, low cost, and small size. IE'S RESP Sensor are available in three packages (110-901, 110-902, 110-904).

### BENEFITS

- Small Size & Low Profile
- Improved stability and low ppb sensitivity
- Accurate & Linear Response
- Long Life (10 +years)
- Fast Response
- Detection of respiratory irritant gases:NO2, Ozone, Chlorines, SO2, H2S and odorous gases.
- Ultra-Low Power < 50 uW max
- ROHS Compliant

### APPLICATIONS

- Outdoor Air Quality
- Indoor Air Quality
- Weather Stations
- Internet of Things
- Smart Homes
- Leak Detection
- HVAC Ventilation Control
- Telemedicine Equipment

### BASIC MEASURING CIRCUIT

The diagram at the right shows the basic measuring circuit of SPEC sensors. The sensor generates an electric current which is converted into sensor output voltage (Vout) by an op-amp/resistor combination.

Notes:  $V_{bias} = V_w - V_r$

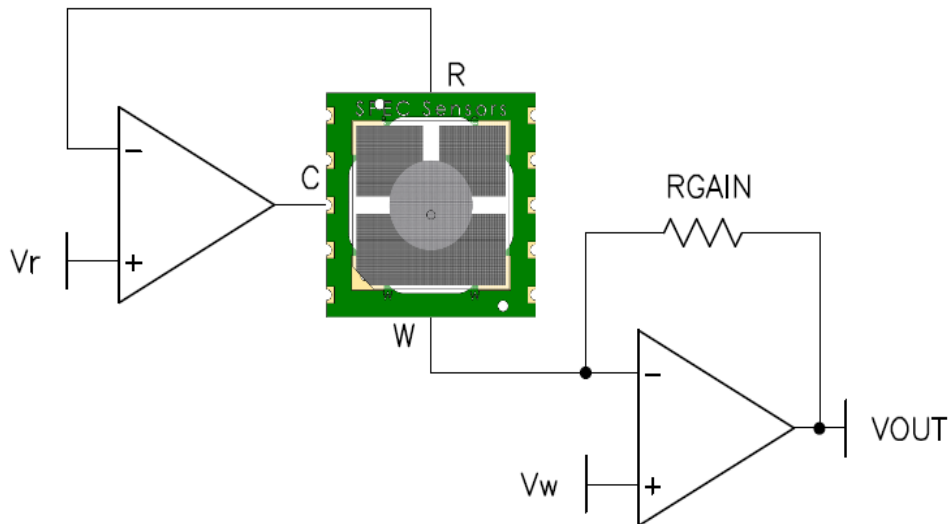

# Respiratory Irritant (RESP) Sensor 110-9XX

## TABLE OF CONTENTS

Description.....	1
Benefits.....	1
Application.....	1
Basic Measuring Circuit.....	1
Specifications.....	3
Cross Sensitivity .....	3
Accuracy.....	4
Linearity.....	4
Temperature effect.....	5
Long term Stability.....	6
Humidity effect.....	6
Important Precautions .....	6
Marking Information .....	7
Ordering Information .....	7
Storage and Handling.....	8
Dimensions 110-901 Pinned Package .....	9
Dimensions 110-902 Thin Castellated Package.....	10
Dimensions 110-903 Thick Castellated Package .....	11

## SPECIFICATIONS

Description	Typical	Unit	Notes
Measurement Range (calibrated as NO2 equivalents)	0 to 20	ppm	1,2,3,5
Lower Detection Limit	0.02	ppm	1,2,5
Resolution	0.01	ppm	1,2,5
Accuracy	± 1	%	1,5
Response Time – T (90)	< 60	seconds	1,5
Sensitivity Range	-50 ± 25	nA/ppm	1,5
Expected Operating Life	10	years	1
Operating Temperature Range	-30 to 55	°C	3,5
Operating Humidity Range	10 to 95	%	3,4,5
Operating Pressure Range	0.8 to 1.2	atm	3
Operating Bias Range	-200	mv	
Power Consumption	10 to 50	uW	2

1. At standard conditions (25 °C, 50% RH, 1 atm), unless otherwise indicated.
2. Depends on circuit design.
3. Recommended operating range, The sensor may be damaged, and warranty voided if operated outside the specified range. For the best optimum accuracy operate sensor at -20 to 40 °C and 15 to 90 % RH.
4. Non-condensing.
5. NO2 equivalents.

## CROSS SENSITIVITY

Most chemical sensors exhibit some cross-sensitivity to other gases. The following table lists the relative response of common potential interfering gases, and the concentration at which the data was gathered.

Gas/Vapor	Concentration PPM	Typical Response as PPM NO2
Nitrogen Dioxide	5 ppm	5.0
Hydrogen	200 ppm	-3.0
Carbon Monoxide	400 ppm	-52.2
Ozone	0.82 ppm	0.2
Sulfur Dioxide	10 ppm	-7.6
Hydrogen Sulfide	10 ppm	-44.0
Ethanol	200 ppm	10.5
Formaldehyde	10 ppm	-6.6
Ethylene	50 ppm	-6.9
Chlorine	10 ppm	2.9
Nitric Oxide	10 ppm	0
Ammonia	100 ppm	0

### REPEATABILITY

The Figure shows response of a set of 56 sensors exposed 4 times 5 ppm NO<sub>2</sub> test gas. Data showed sensors accuracy at 5 ppm within less than ±0.5%. Sensors are calibrated at 5 ppm NO<sub>2</sub> gas.

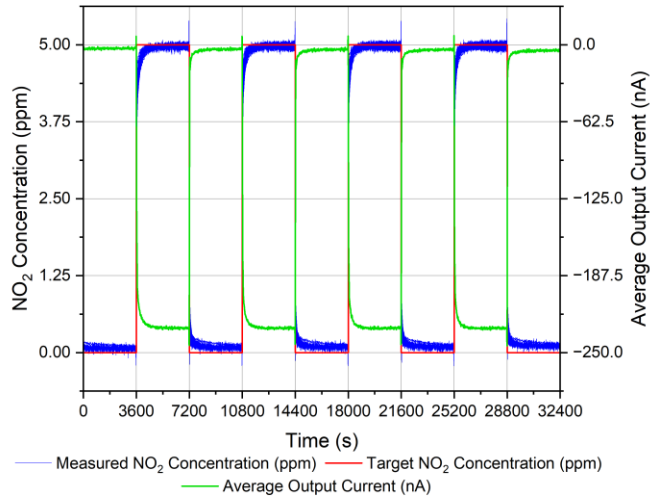

### LINEARITY

The Figure shows response of a set of 56 sensors exposed to 1, 5, 10 and 20 ppm NO<sub>2</sub> test gas. Data showed sensors output is linear from 0 to 20 ppm. Sensors are calibrated at 5 ppm NO<sub>2</sub> gas.

This stepped gas test shows the robustness of the sensor with fast response at each step.

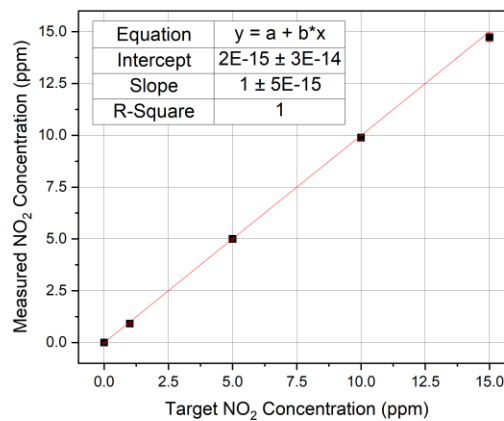
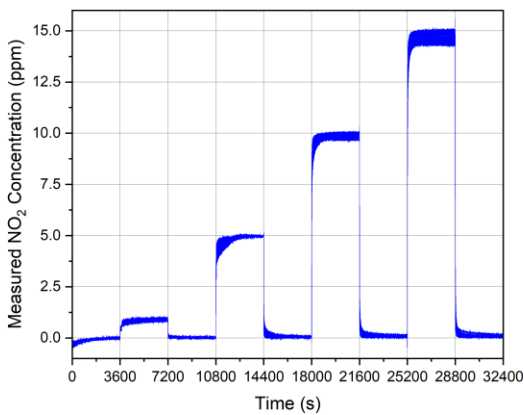

## TEMPERATURE EFFECT

Temperature fluctuations have a predictable, easily compensated effect on the sensor signal. The figures below show the typical Temperature dependency of the output and baseline of RESP sensor under constant humidity of 40-50 % RH. This is a very uniform and repeatable effect, easily compensated for in hardware or software.

### Baseline (Normalized to 20 C):

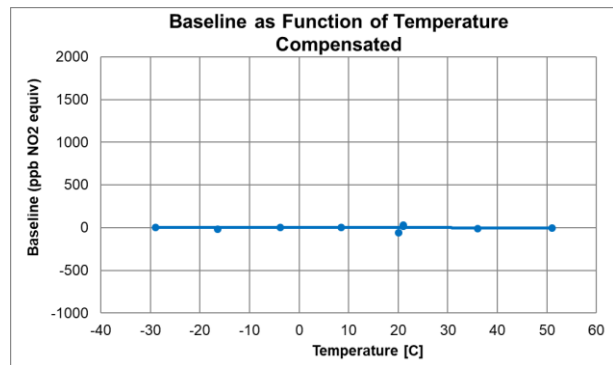
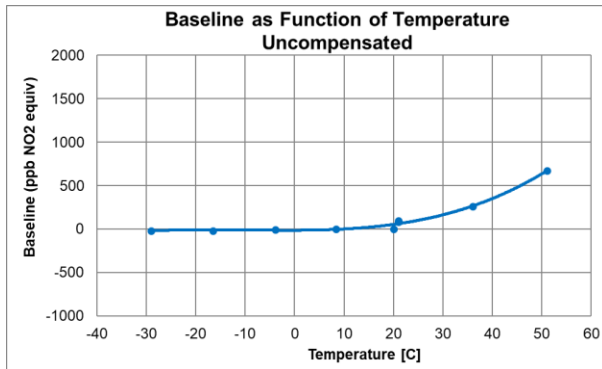

### Sensitivity (Normalized to 20 C):

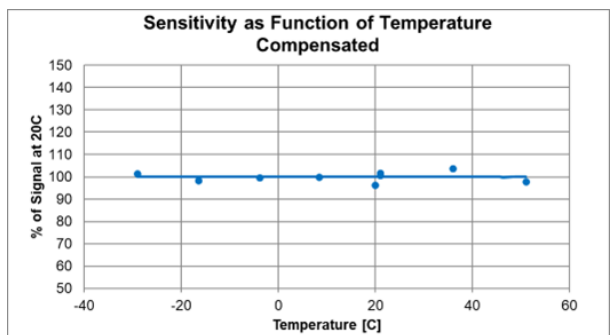
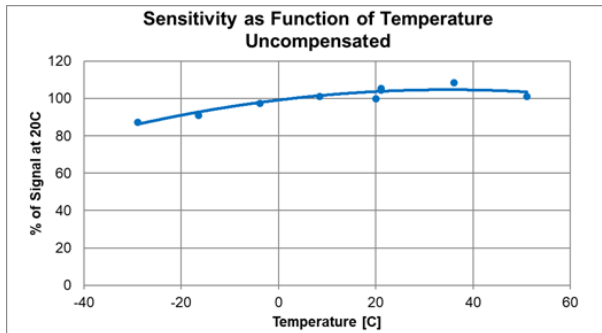

## LONG TERM STABILITY

The figure at right shows the response of a set of 56 RESP Sensors over 14 months under standard test conditions. Sensor output is plotted as % of the initial response to 10ppm NO<sub>2</sub> test gas.

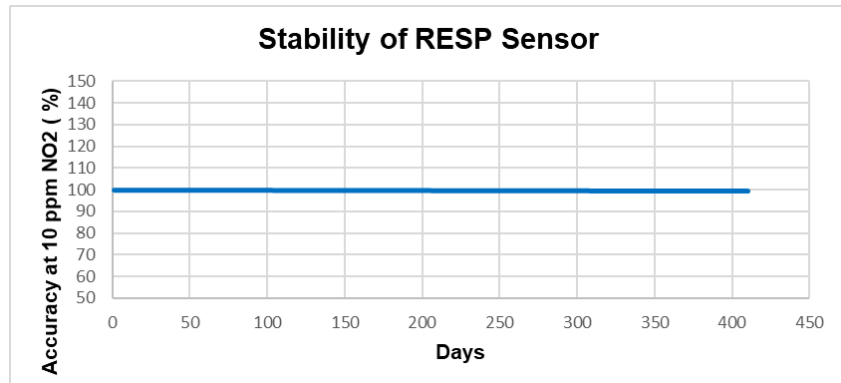

## HUMIDITY EFFECT

SPEC RESP sensors have been tested under a range of humidity conditions to ensure stable response during periodic exposure to varying conditions.

As shown in the figure at right, presenting data collected over 6 weeks, the response of the sensor is virtually unchanged over the first week, and remains within  $\pm 10\%$  of the initial signal over the 6-week test period.

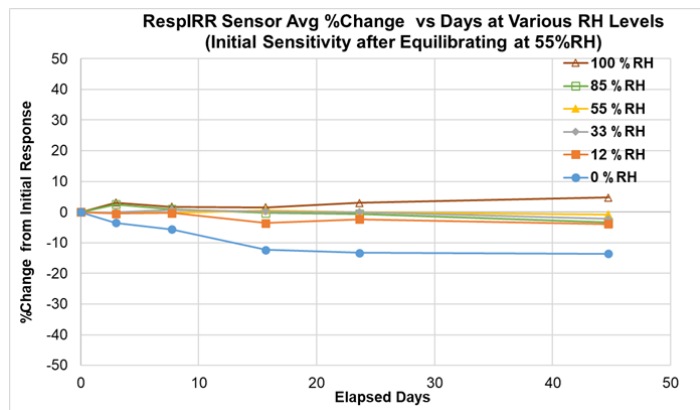

## IMPORTANT PRECAUTIONS

All sensor designs are made for air monitoring @ 1 atm +/- 0.2 atm. Because applications of use and device implementation are outside our control, SPEC Sensors cannot guarantee performance in a given device or application, and disclaims any and all liability, therefore.

**Customers should test under their own conditions to ensure the sensors are suitable for their requirements.**

Contact the factory to discuss specific concerns that might damage the sensor performance or life.

- Condensation and Water (1)
- Saltwater Contamination (1)
- High Temperature Operation (> 70C) for more than 1 month
- Low Humidity Operation (< 15% RH) for more than 3 months
- High Bias voltage
- Highly contaminated air over a prolonged period
- High levels of particles or soot (unless proper filtering is provided)

(1) Use of porous PTFE membrane or filter cap may address this concern)

## MARKING INFORMATION

All gas sensors are tested and marked at the Interlink electronics factory. Sensors include a label with an alpha-numeric code and a two-dimensional bar code. The codes include the information indicated in the table below.

	<b>Sensor Serial Number</b>	<b>Sensor Part Number</b>	<b>Target Gas</b>	<b>Date Code (YYMM)</b>	<b>Sensitivity (nA/ppm)</b>
<b>Alpha-Numeric Code</b>		110901	RESP	2101	-53.32
<b>Two-Dimensional(2D) bar code</b>	010721020248	110901	RESP	2101	-53.32

## ORDERING INFORMATION

Part Number	Package
110-901	Pinned
110-902	Thin Castellation
110-904	Thick Castellation

## SENSOR STORAGE, HANDLING AND SOLDERING

This information embodies various general recommendations concerning the storage, handling, and manual soldering conditions for Sensor. Moreover, sensors are NOT warranted and should NOT be used in high temperature soldering (reflow) or pre-tinning baths.

### Sensor & Module Handling

Handle sensors with care. Take precautions, including but not limited to the following:

- A. DO NOT apply excessive pressure to the top or bottom of the sensor module.
- B. Whenever possible, handle or contact the sensor module from the sides of the PCB or substrate.
- C. Light vacuum pressure is possible during handling, DO NOT apply vacuum over gas sensor port.
- D. If the sealed sensor package is opened, DO NOT re-seal use vacuum or nitrogen gas. DO NOT reseal with desiccant.
- E. DO NOT obstruct the gas sensor port by making direct contact with any tape, apparatus, weights, etc.
- F. DO NOT use silicone or other conformal coatings around the sensor or gas portholes.
- G. Operators are requested to wear powder-free antistatic gloves.

### Manufacturing Assembly Floor Environment

Interlink Electronics recommends that the manufacturing assembly floor environment be maintained at controlled conditions:

- A. Temperature: 18 - 26°C
- B. Relative Humidity: 40 to 60%
- C. Pressure: 1.0 ± 0.2 atm

### Sensor & Module Storage Conditions

The shelf life for sealed, packaged components is 12 months from the pack seal date, when stored in the factory-sealed bag under the following conditions:

- A. Temperature: 5 to 25 °C
- B. Relative Humidity: 20 to 80%
- C. Pressure: 1.0 ± 0.2 atm
- D. Storage Time: 12 months

When moving from Storage Conditions to the Manufacturing Assembly Floor Environment, the sensors should be allowed to equilibrate at the new conditions for at least 24 hours prior to manufacturing.

### Module Attach Soldering Process

Hand solder only. Keep the soldering iron or solder process tool away from the sensor. The sensor should not see pre-heat temperatures above 70 °C. There have been suggested cases where a heat sink cover over the sensor may be applicable to protect the sensor during processing. No Application notes to this approach available. Only to be used as reference only.

- A. DO NOT heat sensor above 70 °C.
- B. Hand or peripheral process type approach
- C. Use solder wire alloy with the lowest possible eutectic temperature.
- D. Use the lowest possible soldering iron temperature.
- E. Contact the host board with the soldering iron at a 45° angle on the solder pad.
- F. Keep the soldering iron away from the top and bottom of the sensor module.
- G. DO NOT place in reflow, wave or IR reflow type processes.
- H. DO NOT place mounted board in a wash.



## 110-901 Pinned Package

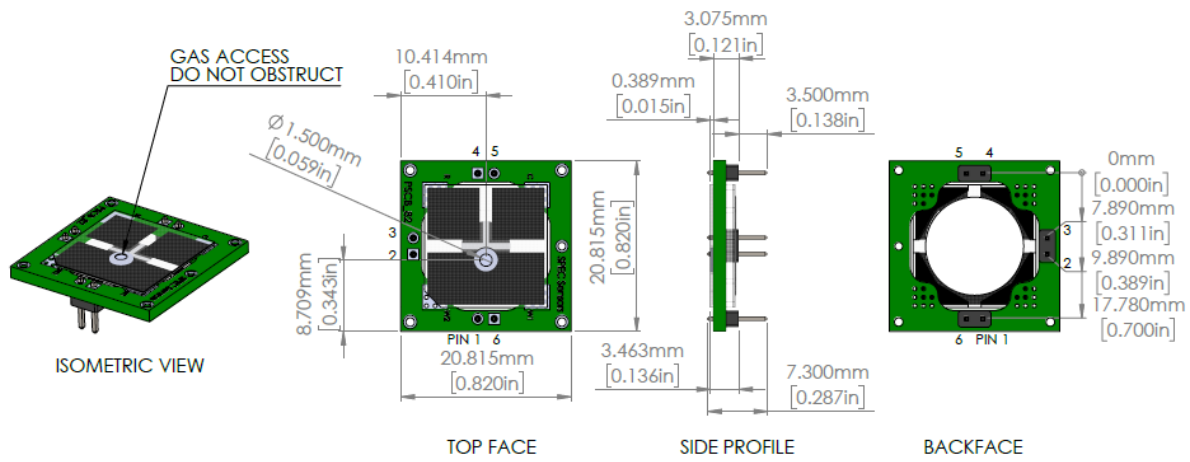

PIN	CONNECTION
1	WORKING
2	N/A
3	N/A
4	REFERENCE
5	COUNTER
6	WORKING

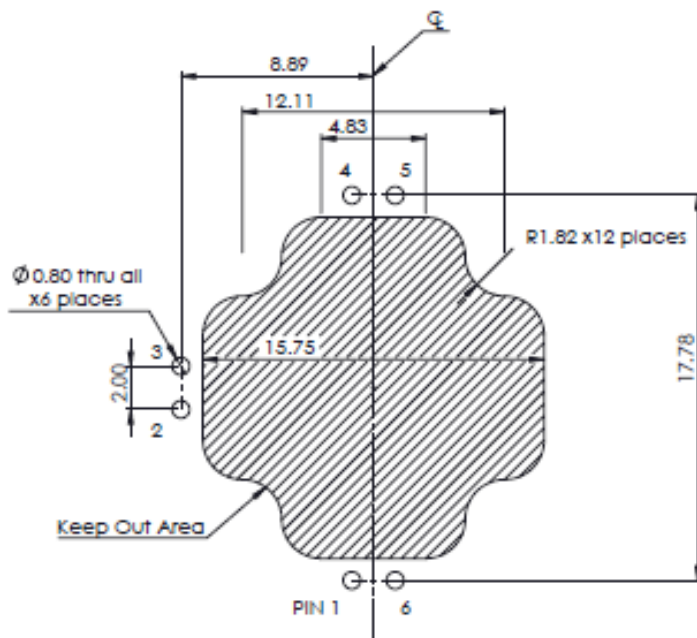

Dimensions are in millimeters

PIN	CONNECTION
1	WORKING
2	NC
3	NC
4	REFERENCE
5	COUNTER
6	WORKING

Notes:  
 -(Ø) 0.8 mm drilled diameter Holes  
 -Recommended Socket  
 (for removable sensor option)  
 PN: 3M 950502-60102-AR  
 -if using socket, keep out area  
 may not be required. Use caution.

## 110-902 Thin Castellation Package

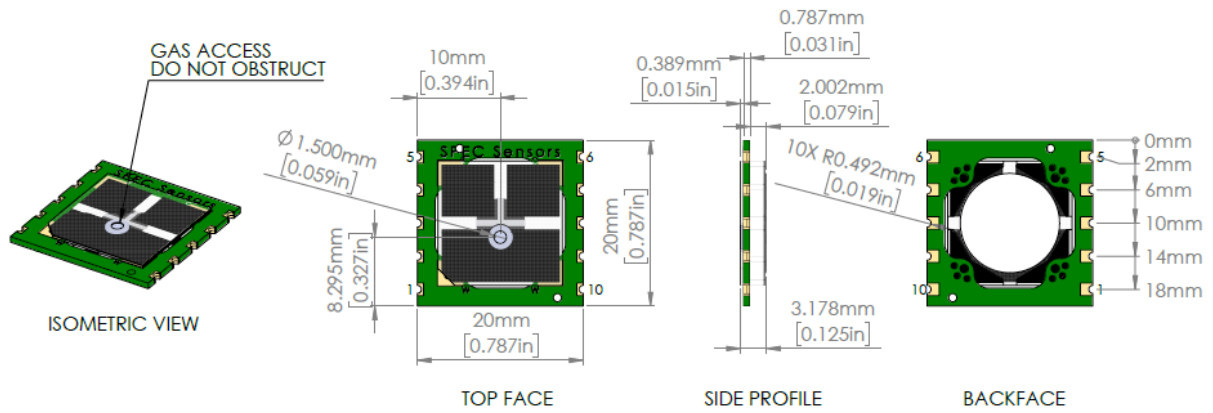

PIN	CONNECTION
1	WORKING
2	NC
3	NC
4	NC
5	REFERENCE
6	COUNTER
7	NC
8	NC
9	NC
10	WORKING

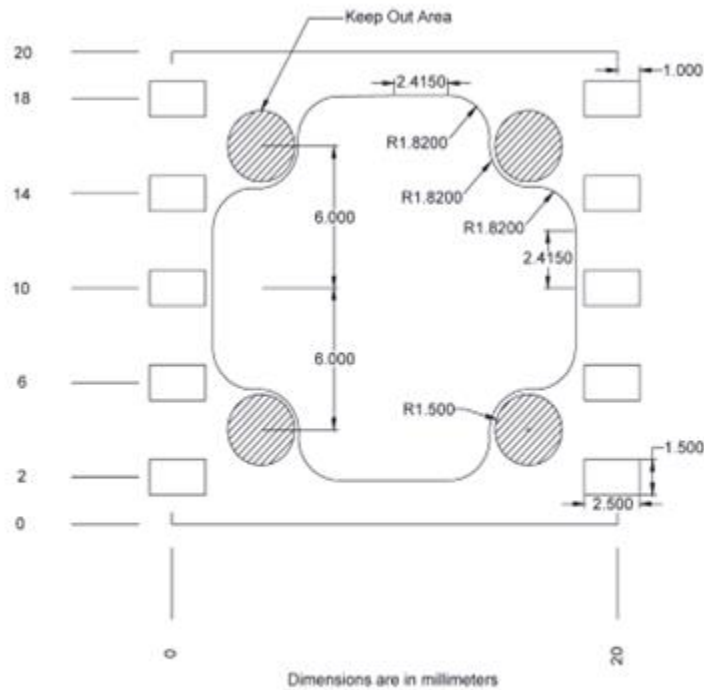

## 110-904 Thick Castellation Package

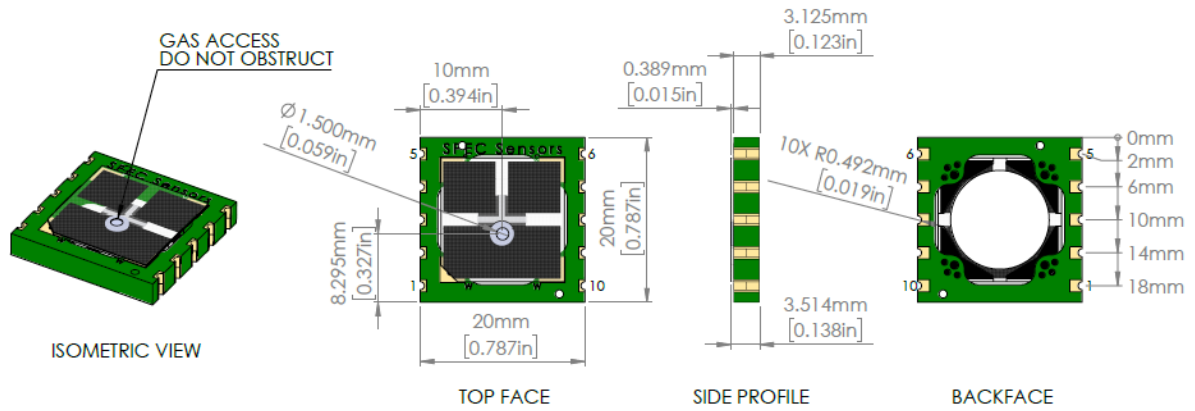

PIN	CONNECTION
1	WORKING
2	NC
3	NC
4	NC
5	REFERENCE
6	COUNTER
7	NC
8	NC
9	NC
10	WORKING

